

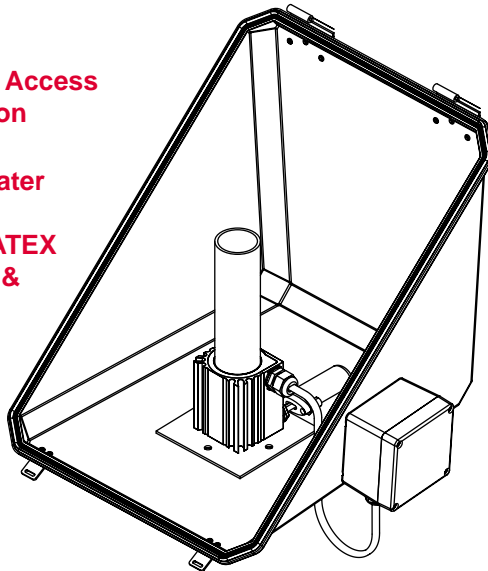

VIPAK® FPH FINNED PIPE HEATER

The NEW O'Brien Finned Pipe Heater (FPH) slides over any 2" pipe stand such as our IPB series. The space-saving FPH improves accessibility and adjustability within the enclosure.

- Economical
- Space Saving
- Easy Installation & Access
- Provide winterization down to -20°F
- Self Regulating Heater
- General Purpose, Class I Div 2, and ATEX
- Available 115, 230, & 277 VAC



FPH

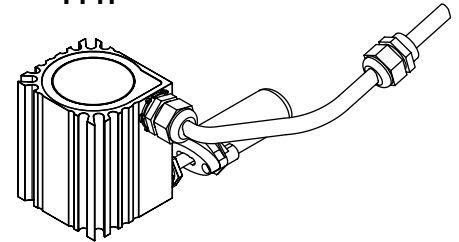

OPTIONAL JUNCTION BOX

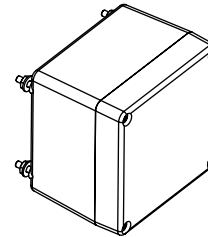

Performance

Enclosure	Freeze Protection Down To	Max Enclosure Temp @ 104F
C5	-25F (-32°C)	170°F (77°C)
A1	-20F (-30°C)	170°F (77°C)
C14	-15F (-26°C)	170°F (77°C)
A2	-10F (-23°C)	170°F (77°C)
A701 or A702	-10F (-23°C)	170°F (77°C)

Circuit Loading

Start-up @ -25°F (-32°C)	
120V	1.7A
230V	0.9A
277V	0.7A

Model Number

Model Code	Description	Availability		
		General Purpose	CL I, Div 2	ATEX
FPH	Finned Pipe Heater	X	X	X
Operating Voltage				
1		X	X	X
2		X	X	X
3		X	X	X
Approvals				
GP		X	NA	NA
D2		NA	X	NA
A1		NA	NA	X
Options				
J		X	X	NA
EJ		X	X	X



VIPAK® FPH FINNED PIPE HEATER

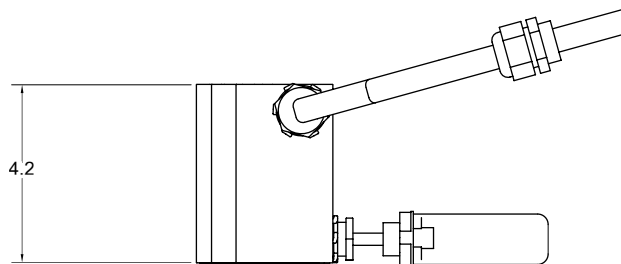
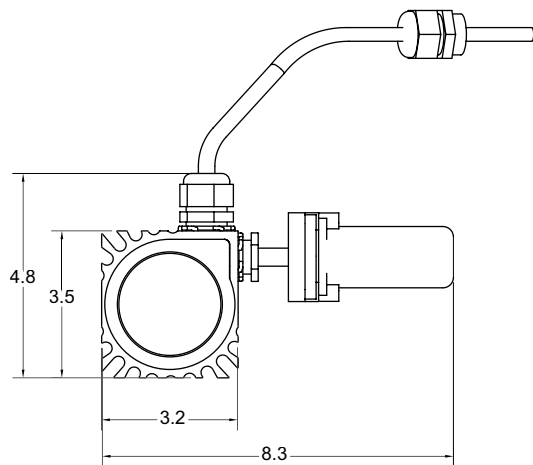

Specifications subject to change without notice.

©2004 O'Brien Corporation • QLT-A501SPEC • 1 MAR 04



Worldwide Offices:

USA: 1900 Crystal Industrial Court • St. Louis, Missouri 63114 • Ph: 314/236-2020 • Fax: 314/236-2080

BELGIUM: Mallekotstraat 65 • B 2500 Lier, Belgium • Ph (+32) 3 491 9875 • Fax (+32) 3 491 9876

CANADA: Suite 400 • 609 14th Street NW • Calgary, AB T2N 2A1 • Ph 403/730-7277 • Fax 403/730-7279

obcorp@obcorp.com • www.obcorp.com