



V96 Series Rising Stem Plug Valves

Pressure Ratings up to 6000 psig (413 bar)

Catalog No. V96-4
June 2008

Features

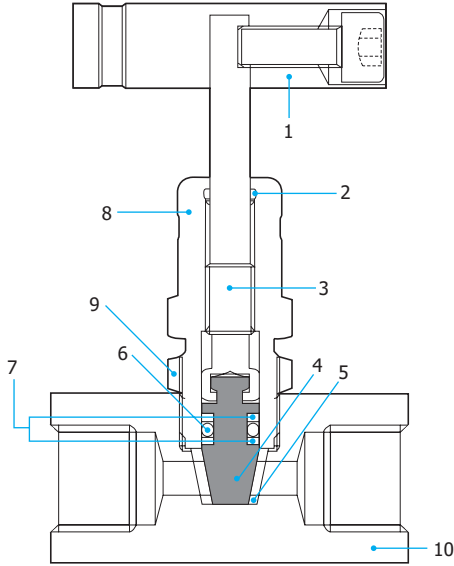

- Bi-directional flow control.
- Straight-through orifice hence roddable for easy cleaning.
- Replaceable seat design: Acetal seat standard, optional PEEK and PFA.
- Non-rotating Stem Tip for positive sealing and maximum soft seat life.
- Internal bonnet O-ring protects threads from external contamination.
- Isolated threads located above sealing rings prevents media contamination and thread lubricant washout.

Materials of Construction

Component	Grade/ASTM Specification
1. Handle, Set screw	SS316 / A276
2. Bonnet O-ring	FKM O-ring
3. Stem Shank	SS316 / A276, A479
4. Stem Tip	
5. Seat	Acetal/D4181, optional PEEK, PFA
6. Stem tip O-ring	FKM O-ring
7. Backup rings (2)	PTFE/D1710
8. Bonnet	SS316/A276
9. Locking nut	
10. Body	SS316/A276, A479

Wetted components are listed in blue.

Lubrication:

Fluorocarbon base on threads, silicone base on soft parts

Technical Information

Pressure-Temperature

Ratings are based on standard stem tip of FKM O-ring and PTFE backup rings.

Body Material	SS316		
	Acetal	PEEK	PFA
Seat			
Temperature °F (°C)	Working Pressure, psig (bar)		
-20 to 100 (-28 to 37)	6000 (413)	6000 (413)	750 (51.6)
200 (93)	2650 (182)	3000 (206)	625 (43.0)
250 (121)	1000 (68.9)	1600 (110)	450 (31.0)
300 (148)	-	1300 (89.5)	300 (20.6)
350 (176)	-	1200 (82.6)	200 (13.7)
400 (204)	-	1000 (68.9)	100 (6.8)

Valve with Acetal seat: For water and steam application, standard valve with Acetal seat is not recommended for application of greater than 200 °F (93 °C) temperature.

Temperature Range

Optional O-ring materials

O-ring Material	Designator	Temperature Range °F (°C)
Buna C	BC	-65 to 250 (-53 to 121)
Buna N	BN	-20 to 250 (-28 to 121)
EPDM	EP	-20 to 250 (-28 to 121)
Kalrez	KZ	-20 to 400 (-28 to 204)

Flow Efficiency at 100°F (37 °C)

Flow Curves

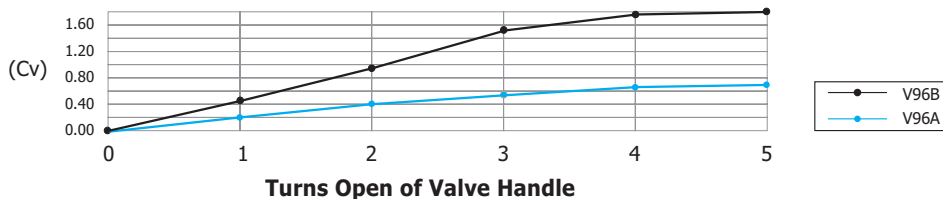

Testing

Every valve is factory tested with the nitrogen gas @ 1000 psig (68 bar) for leakage at the seat to a maximum allowable leak rate of 0.1 SCCM. Stem seals are tested to a requirement of no detectable leakage using a liquid leak detector.

<p>Quality System Approvals</p>	<p>Dk-Lok Tube Fitting Certification Listing</p>	<p>D-Pro Valve Certification Listing</p>	<p>THE POWER OF RELIABILITY DK TECH CORPORATION www.dklok.com</p>
---------------------------------	--	--	---

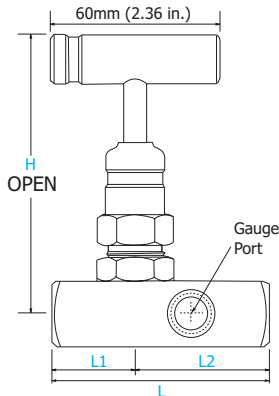

Gauge Port Valves

- V96A-G4 series
- V96B-G8 series



Ordering information and Dimensions

Basic Ordering Number	End Connections		Orifice mm(in.)	Cv	Dimensions, mm(in.)				
	Inlet	Outlet			L	L1	L2	H	
V96A-	F-4N	1/4 in. Female NPT		4.8 (0.187)	0.63	56.9 (2.24)	28.4 (1.12)	28.4 (1.12)	95.8 (3.77)
	MF-4N	1/4 in. Male NPT	1/4 in. Female NPT			73.4 (2.90)	45.2 (1.78)		
	MF-8N4N	1/2 in. Male NPT	1/4 in. Female NPT			76.5 (3.01)	48.0 (1.89)		
V96A-G4*	F-4N	1/4 in. Female NPT		6.4 (0.25)	1.8	72.9 (2.87)	28.4 (1.12)	44.4 (1.75)	97.3 (3.83)
	MF-8N4N	1/2 in. Male NPT	1/4 in. Female NPT			124 (4.87)	79.2 (3.12)		
V96B-	F-8N	1/2 in. Female NPT		6.4 (0.25)	1.8	67.6 (2.66)	33.8 (1.33)	33.8 (1.33)	97.3 (3.83)
	MF-8N	1/2 in. Male NPT	1/2 in. Female NPT			88.6(3.49)	54.9 (2.16)		
	MF-12N8N	3/4 in. Male NPT	1/2 in. Female NPT			90.9 (3.58)	33.8 (1.33)		
V96B-G8*	F-8N	1/2 in. Female NPT		6.4 (0.25)	1.8	142 (5.58)	84.6 (3.33)	57.2 (2.25)	97.3 (3.83)
	MF-8N	1/2 in. Male NPT	1/2 in. Female NPT						
	MF-12N8N	3/4 in. Male NPT	1/2 in. Female NPT						

All dimensions shown are for reference only and are subject to change.

- V96A-G4* gauge port: 1/4 in. Female NPT, V96B-G8*: 1/2 in. Female NPT.
- Gauge port valves with pipe insulation extended body of 2.0 in. (50 mm) are listed in blue.



Panel Mounting option

Panel hole drill size 25/32 in. (19.8 mm), max. panel thickness 1/2 in. (12.7 mm).
To order, add - **PM** as a suffix to the valve ordering number. Example: V96A-F-4N-**PM**

Sour Gas Service option

Materials are selected in accordance with NACE standards.
To order, add - **SG** as a suffix to the ordering number. Example: V96A-F-4N-**SG**

How to order

Select desired valve basic ordering number, and applicable options from designators listed below.

Example: V96A-F-4N **- PK** **-EP** **-PM** **- SG** **- S**

Seat Designator	Stem tip O-ring Designator	Panel mounting Designator	Sour Gas Designator	Body Material Designator
<ul style="list-style-type: none"> • Nil: Acetal • PK: PEEK • PA: Teflon PFA 	<ul style="list-style-type: none"> • Nil: FKM O-ring • EP: EPDM • KZ: Kalrez • BC: Buna C • BN: Buna N 	<ul style="list-style-type: none"> • PM: Panel Mounting 	<ul style="list-style-type: none"> • SG: Sour Gas 	<ul style="list-style-type: none"> • S: SS316

We reserve the right to change specifications stated in this catalog for our continuing program of improvement.

Safe Valve Selection

The selection of a valve for any application or system design must be considered to ensure safe performance.

Valve function, valve rating, material compatibility, proper installation, operation and maintenance remain the sole responsibility of the system designer and the user. Dk Tech accepts no liability for any improper selection, installation, operation or maintenance.

 THE POWER OF RELIABILITY DK TECH CORPORATION www.dklok.com	DK TECH Trademarks   		DK TECH contact information Tel. (82) 55-338-0114 Fax (82) 55-338-6745 E-mail: sales@dklok.com	For International customers Tel. (82) 55-338-0031/2 Fax (82) 55-338-6746 E-mail: dklok@dklok.com
	Mailing Address 826, Naesam-Ri, Juchon-Myeon, Gimhae-City, Gyeong Nam, Korea 621-841			